

Payroll System

Payroll System

Overview :

Payroll System helps to reduce your cost of operations. It enables users to set statutory regulations like PF, ESI , PT,ESIC , ECR and Professional Tax dynamically depending on the earning slabs and government regulations. It provides flexibility in defining various allowances, deductions, salary structures etc. for the employees and all formula for PF, EPF, ESIC, Profession Tax, Income Tax etc. are definable and changeable at user's end. This software can be integrated with Time attendance machine / software.

The set of features include:

- Payroll Processing
- Pay slip generation
- Statutory and Bank Reporting
- Tax Calculation
- Import/export from/to Excel

Payroll System

Payroll System

Key Features :

- Saves the time and lowers the error ratio
- Simplify TDS(Income Tax) processing by computing the data
- Integrate with time attendance machine
- User define Allowances , Deduction (Set your Own Formula / Fixed Pay / Annualized Pay etc.)
- View employee payment history at any time
- Master Data Import facility- employees info as well as attendance from excel sheet
- Different tax forms related to PF,ESI,TDS are available
- Single or batch printing of reports
- Salary Arrears adjustment
- Maintain all the information of salary structure, salary transfer and employee records
- Lock month facility to avoid changes in processed data
- It guarantees an accurate salary processing, employee statutory deductions & employer statutory contributions with the help of predefined processes

Payroll System

Payroll System



Functional Diagram:

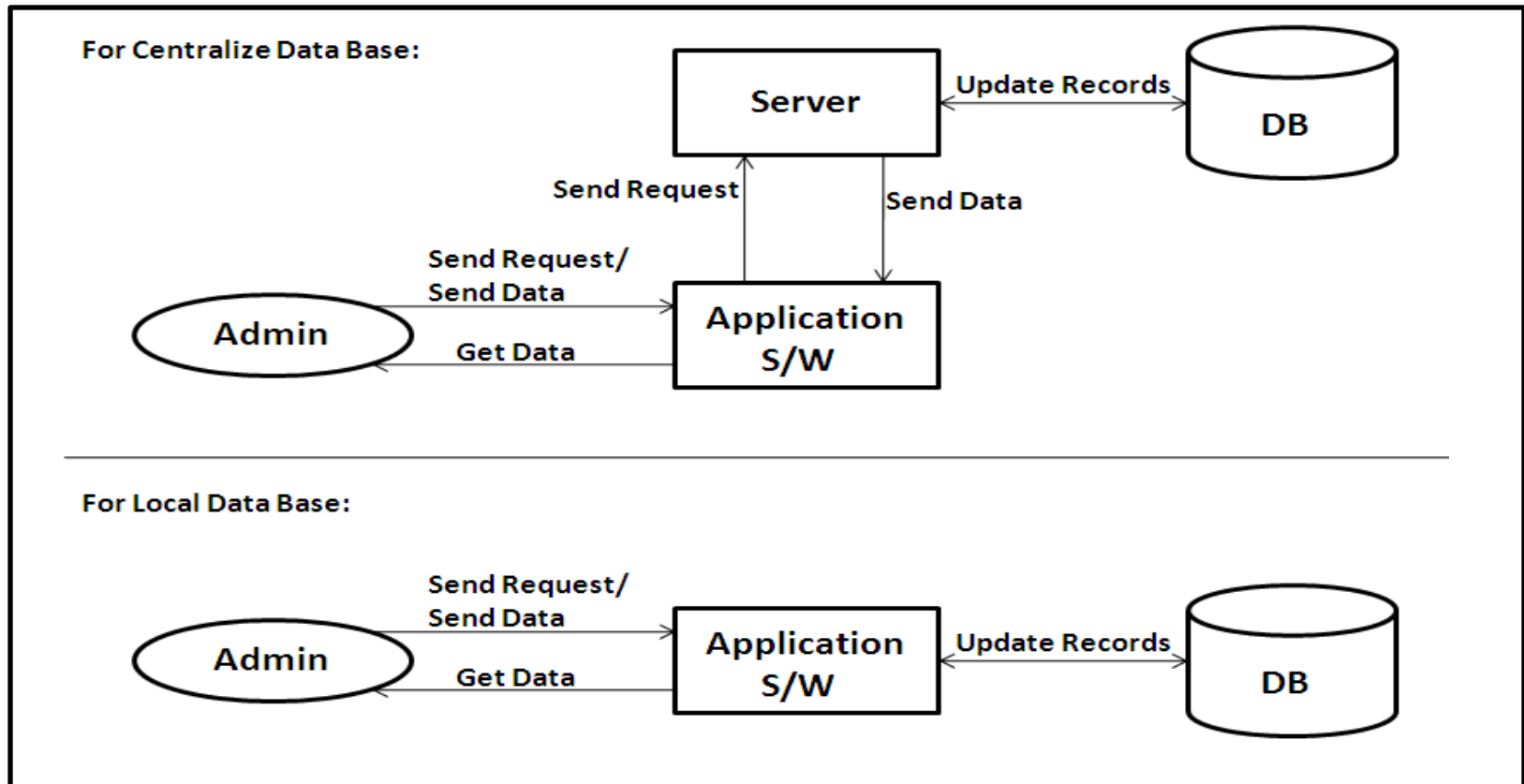

Payroll System

Payroll System

Benefits:

▪ Flexible Structure building capability for salary structure:

In this system it is very easy to define different salary structures with different rules such PT,PF,ESI,TDS applicable or not , holiday/weekly off paid or not, Basic and OT rates fixed or employee wise. Flexibility to add different rates and selection of different heads.

▪ Totally user defined Rules for Allowances & Deductions:

This system is flexible to add or remove number of salary heads having user defined entry field with unmatched flexibility for Formula, slab, fixes amount with customized calculation.

▪ PT,PF,ESI Calculations:

User define setting is available for calculation of PT,PF,ESI. Automatic calculations of different terms related to PF, ESI take place. Different forms and reports related to each are available.

▪ Income Tax Management:

Auto calculation of TDS based on different projection such as exemptions & deductions take place. If TDS applicable then amount of projected TDS is deducted from monthly salary.

▪ Bonus, Loans & Advance Management:

User can define Bonus/Loans/Advances. Auto recovery of EMI & stops automatically once the loan amount is fully recovered. Calculation of Interest on Loans based on Flat Interest, Reducing Balance available.

▪ Late Penalty & Attendance Bonus Management:

User can define different formula to calculate late penalty and attendance bonus and also apply these rules to only selected employee or to all employee.

▪ Import Export Data:

User can import the master data as well as attendance data. Also there is facility to export master data.

▪ Intelligent Reporting:

Different types of report related to salary are available such as salary slip, salary history , PF-Form5, PF-Form10, PF-Form12A,ESI Form5, ESI Challan, ECR Challan, ESIC Report, TDS Form16, TDS Details, different employee related reports.

▪ User Friendly :

- Software has been designed in such a way as to be easy to use or operate:
- Simple to install
- Easy to update
- Efficient
- Effective error handling

Payroll System

Payroll System

Reports:

▪ Monthly Reports

- Salary Slip
- Salary Report In Excel
- Attendance Summary

▪ Statutory Report

- PT Report
 - PT Statement
- PF Report
 - PF-Form 5
 - PF-Form 10
 - PF-Form 12A
 - PF Statement
 - ECR Challan
 - PF Covering Letter
- ESI Report
 - Monthly ESI Report
 - ESI Form-5
 - ESI Challan
 - ESIC Report

▪ TDS Report

- Form 16
- TDS Details

▪ Pre-salary Reports

- Advance
- Loan
- Bonus

▪ Employee Related Reports

- Employee Salary History
- Employee Net Salary Report
- Employee Master Report
- New Joinees report
- Employee Increment Report

▪ Bank Slip

Note: Sample Reports available on request

Payroll System

Payroll System

System Requirement:

Server Software Requirement(Any 1 of the following)

- Microsoft Windows Server 2003, any edition for x86 (32-bit) or x64 (64-bit) platform, with/without any Service Pack
- Microsoft Windows Server 2008, any edition for x86 (32-bit) or x64 (64-bit) platform, with/without any Service Pack
- Microsoft Windows 7, any edition for x86 (32-bit) or x64 (64-bit) platform, with/without any Service Pack
- Microsoft Windows XP with Service Pack 3

Database Requirement (If Database is Local)

Xampp -win32-1.8.1

Supporting Software

- Microsoft .NET framework version 2.0 or later
- Microsoft Internet Information Services (IIS) 5.1 or later, depending on the underlying operating system
- Microsoft Windows Installer version 3.1 or later
- Crystal Reports for .Net Framework 4.0

Other Recommended Software

The following client software applications are recommended to access additional features:

- Adobe Acrobat Reader version 7 or higher is required to open documents exported from our software in PDF format.
- Microsoft Office 2007 or Microsoft Office 2003 with Microsoft Office 2007 compatibility pack is required to open documents exported from our software.

Hardware Requirement :

- Minimum: 2 GB of RAM
- 200 MB of available hard disk space

- Processor: Dual Core & Above
- Recommended Bandwidth: 512 Kbps & Above



Payroll System

Payroll System

Ordering Information:

<u>Model No</u>	<u>Description</u>
CPR-Standard	Payroll software with front end as VB.Net and Back end as My SQL Supports upto 500 employees.
CPR-EE	Payroll Software extention of 100 employee.
Web-Pay	Payroll Software Service with centralized data base on Web server.
Web-Pay Renewal	Service Renewal yearly after first year